

CCHP –Finalize field testing of cold climate heat pump (CCHP) based on tandem vapor injection compressors (Regular)– FY17 2nd Quarter Milestone Report



**Approved for public release.
Distribution is unlimited.**

Bo Shen
Van Baxter
Omar Abdelaziz
Keith Rice
03/31/2017

DOCUMENT AVAILABILITY

Reports produced after January 1, 1996, are generally available free via US Department of Energy (DOE) SciTech Connect.

Website <http://www.osti.gov/scitech/>

Reports produced before January 1, 1996, may be purchased by members of the public from the following source:

National Technical Information Service
5285 Port Royal Road
Springfield, VA 22161
Telephone 703-605-6000 (1-800-553-6847)
TDD 703-487-4639
Fax 703-605-6900
E-mail info@ntis.gov
Website <http://www.ntis.gov/help/ordermethods.aspx>

Reports are available to DOE employees, DOE contractors, Energy Technology Data Exchange representatives, and International Nuclear Information System representatives from the following source:

Office of Scientific and Technical Information
PO Box 62
Oak Ridge, TN 37831
Telephone 865-576-8401
Fax 865-576-5728
E-mail reports@osti.gov
Website <http://www.osti.gov/contact.html>

This report was prepared as an account of work sponsored by an agency of the United States Government. Neither the United States Government nor any agency thereof, nor any of their employees, makes any warranty, express or implied, or assumes any legal liability or responsibility for the accuracy, completeness, or usefulness of any information, apparatus, product, or process disclosed, or represents that its use would not infringe privately owned rights. Reference herein to any specific commercial product, process, or service by trade name, trademark, manufacturer, or otherwise, does not necessarily constitute or imply its endorsement, recommendation, or favoring by the United States Government or any agency thereof. The views and opinions of authors expressed herein do not necessarily state or reflect those of the United States Government or any agency thereof.

Title

**BTO Project 3.2.2.26
FY17 2nd Quarter Milestone Report**

**CCHP -
Finalize field testing of prototype cold climate heat pump (CCHP) based on
tandem vapor injection compressors**

Authors

Bo Shen, Van Baxter, Omar Abdelaziz, Keith Rice

Date: 03/31/2017

Prepared by
OAK RIDGE NATIONAL LABORATORY
Oak Ridge, TN 37831-6283
managed by
UT-BATTELLE, LLC
for the
US DEPARTMENT OF ENERGY
under contract DE-AC05-00OR22725

Executive Summary

This report describes the system diagram and control algorithm of a prototype air-source cold climate heat pump (CCHP) using tandem vapor injection (VI) compressors. The prototype was installed in Fairbanks, Alaska and underwent field testing starting in 09/2016. The field testing results of the past six months, including compressor run time fractions, measured COPs and heating capacities, etc., are presented as a function of the ambient temperature. Two lessons learned are also reported.

1. System Diagram and Control Algorithm

The researchers applied an innovative configuration that allows for improved capacity modulation based on equal-size tandem VI scroll compressors. VI compressors are less prone to capacity degradation with decreasing the ambient temperature, and the compressor discharge temperature is lower than non-VI compressors. The proposed control algorithm facilitates efficient operation over a wide range of ambient conditions.

The figure below illustrates the hardware system configuration.

- The tandem VI compressors are coupled with an inter-stage flash tank to separate phases and feed saturated vapor to the compressors' VI port.
- A suction line accumulator, an injection line accumulator, a liquid receiver and the inter-stage flash tank are used as charge buffers. The liquid receiver is connected to four one-way check valves (3, 4, 5, and 6) to maintain consistent inlet and outlet lines for both heating and cooling modes. The suction line accumulator and the injection line accumulator protect the compressors from liquid refrigerant entering.
- Two fixed-orifices are installed upstream and downstream of the flash tank to provide throttling, and control the suction and injection pressures for heating mode.
- An electronic expansion valve (EXV) is installed upstream of the liquid receiver to optimize the injection pressure as a function of the ambient temperature and compressor staging.
- Two check valves (1, 2) are installed to control the flow direction for cooling, heating and defrosting modes.
- A separate TXV is used for cooling mode only.
- A four-way valve is used to change the refrigerant flow direction as a typical heat pump does.
- It uses a two-speed indoor blower.

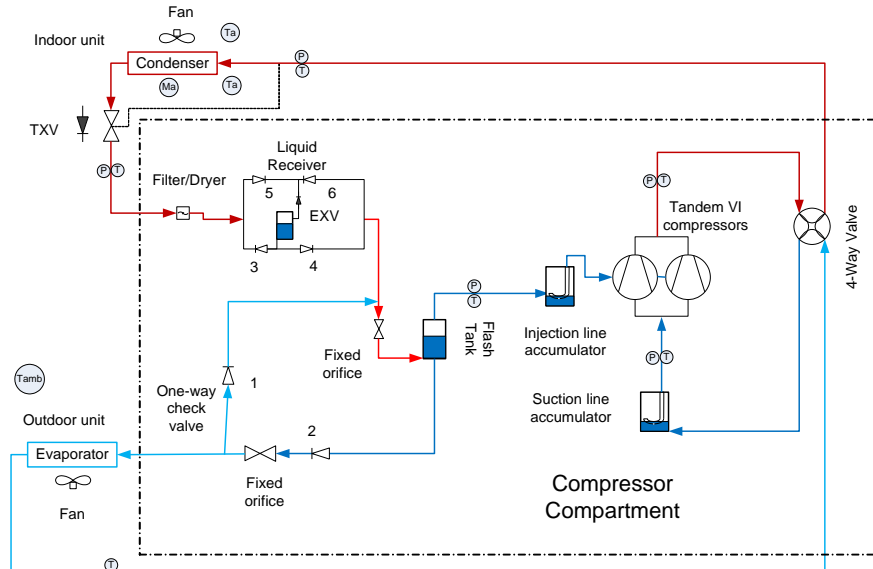

Figure 1: Refrigeration cycle schematic: air-source CCHP using tandem VI compressors, inter-stage flash tank, and optimum inter-stage pressure control

The proposed control algorithm facilitates an extensive range of operating conditions with optimized efficiency, comfort level and adequate capacity to match the building load.

1. The control works with a conventional two-stage thermostat, i.e. having two 24 V signals, Y1 (low stage) and Y2 (high stage) calls.
2. The heat pump is sized to match the building cooling load using only one compressor with the VI port closed. That means, in cooling operation, only one compressor is used with the indoor blower set at low speed.
3. In heating mode, both compressors are used below a certain ambient temperature (which could be set by the installing contractor), for example, $<20^{\circ}\text{F}$. At higher, more moderate winter ambient temperatures only one compressor operates. This prevents running both compressors unnecessarily at low building load conditions, and allows the single-compressor to run longer time with unloaded heat exchangers and good efficiency.
4. In heating mode, the low and high air flow rates of the indoor blower respond to the calls of Y1 and Y2 respectively. However, when the ambient temperature is higher than a factory setting, e.g. 42°F , the indoor blower will always run high air flow rate, whenever there is a heating call. This allows reduced supply air temperature and compressor head pressure at moderate ambient temperatures. This will, in turn, boost the heat pump efficiency without sacrificing comfort.
5. The control has an “economy” mode and a “comfort” mode. During the “economy” mode, the indoor blower will adjust its stage to match the compressor stage, i.e. low air flow rate to match the Y1 call, and high air flow rate to match the Y2 call. During the “comfort” mode, the indoor air flow will be adjusted according to the heat pump supply air temperature. If the supply air temperature is lower than a set value, the indoor air flow will be turned to the low setting resulting in warmer supply air.
6. Opening of the EXV is controlled as a function of ambient temperature and the compressor staging and indoor air flow rates. The aim is to adjust inter-stage pressure, keeping the pressure ratios of the low stage compression (from compressor suction to inter-stage) and high stage compression (from inter-stage to compressor discharge) approximately equal. This enables optimum efficiency operation over a wide range of ambient temperatures, with running one or two compressors.
7. At present, when running one compressor, the EXV is fully open at the ambient temperatures $>47^{\circ}\text{F}$, and the EXV has a minimum opening at the ambient temperatures $<17^{\circ}\text{F}$. When running two

compressors, the EXV is fully open at the ambient temperatures $>17^{\circ}\text{F}$, and has a minimum opening at the ambient temperatures $<-13^{\circ}\text{F}$.

8. The EXV control and two properly-sized orifices, upstream and downstream of the injection port, makes the VI compressors coupled with the flash tank work in a wide range and avoid injection overfeeding or underfeeding.
9. The EXV control functions impact the migration of the refrigerant charge between the four charge buffers, i.e. liquid receiver, flash tank, suction line accumulator and injection line accumulator.
10. In cooling and defrosting modes, the EXV is fully open.

2. Field Testing

We collaborated with the Cold Climate Housing Research Center (CCHRC) in Fairbanks, AK and used their lab space to host the field investigation. This site doesn't necessarily represent a typical residential or commercial building but was readily available and allowed the CCHP to experience a very harsh winter. Heating season operation started 09/2016. The prototype (Figures 2 and 3) was constructed starting with a modified Rheem 4.5-ton heat pump unit (15.5 SEER, 9.15 HSPF, outdoor unit Model No: RPRL061JEC, indoor unit Model No: RHPLHM6024JC.). During the field test, the CCHP successfully ran down to -30°F (-35°C), with heating capacity $>75\%$ of the rated capacity, and heating COP > 1.8 .



Figure 2: Indoor Unit, Compressor Compartment and Data Acquisition of Field Testing Heat Pump in Fairbanks, Alaska



Figure 3: Outdoor Unit of Field Testing Heat Pump in Fairbanks, Alaska

We developed and debugged a data acquisition (DAQ) system for the field data monitoring and control implementation. A DAQ controller and measurement devices (from National Instruments Inc.) were used to monitor the field operations. These were connected to an indoor host computer to process and store the data. The field testing data are sent back to ORNL through Dropbox via internet connectivity.

Figure 1 describes the system diagram and instrumentation, where P represents refrigerant pressure transducers; T represents refrigerant side temperature measurements (all inserted probe thermocouples, except the one soldered on the evaporator exit tube surface); T_a means air side temperature measurements; T_{amb} means an ambient temperature measurement; Ma means the indoor air flow measurement using an air flow monitor having an array of pitot tubes.

The air temperatures flowing in and out of the indoor air handler were measured using T-type thermocouples. Three thermocouples were evenly placed at the entrance of the indoor unit to measure the average return air temperature. At the exit of the indoor blower, three thermocouples were used to monitor the supply air state. Four pressure transducers were used to measure the refrigerant pressures entering and leaving the indoor coil, as well as entering and leaving the compressors. Another pressure transducer was used to measure the pressure entering the injection port. Four Ohio Semitronics Watt transducers were used to measure the powers of the outdoor fan, indoor blower and two compressors, individually. The DAQ system scanned all the sensors and recorded the data every half minute.

The field testing was monitored from 09/2016 to 03/2017. The CCHP operated down to -30°F (-35°C). Figure 4 illustrates the run time fraction of the second compressor to the total heat pump run time, changing with the ambient temperature. It can be seen that the second compressor operated more frequently as ambient temperature fell below 5°F . At -30°F (-35°C), the second compressor was still cycling at a 90% fraction, indicating that the prototype CCHP system still had reserve heating capacity and was able to approximately meet the heating load of the lab space even at this extreme cold condition.

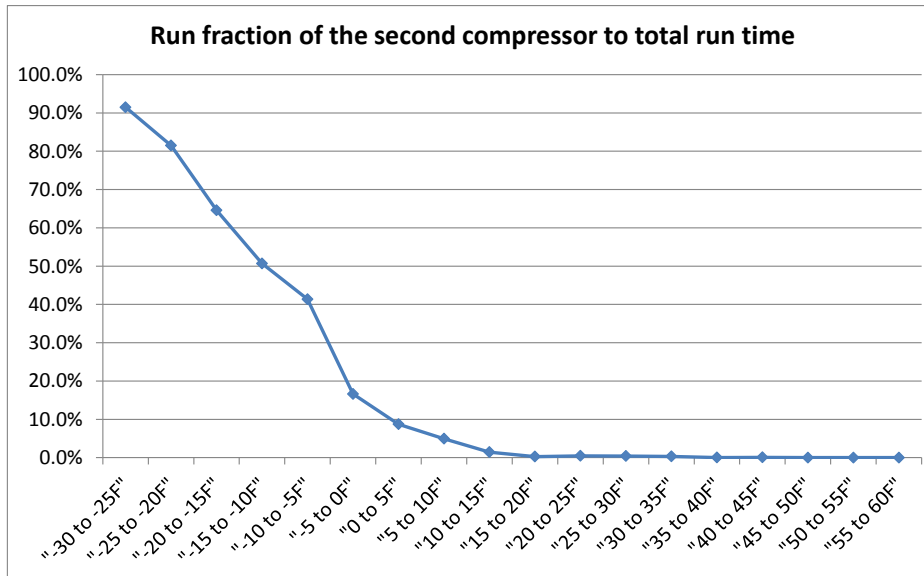

Figure 4: The second compressor run fraction, relative to the total run time versus ambient temperature

Figure 5 shows the field-measured average delivered heating capacities for each outdoor temperature bin for both single and dual-compressor operation. At -30°F (-35°C), with two compressors, the average delivered capacity was 27,000 Btu/h (7.9 kW). This is 75% of the nominal rated heating capacity of the “starting point” heat pump unit at 47°F (8.9°C) or 36,000 Btu/h (10.6 kW). Note that the average bin heating capacity decreases as the ambient temperature drops to ~5°F (only one compressor operating for majority of the time). As the outdoor temperature decreased from 5°F to -30°F, the second compressor began running for an increasing portion of the time and the average bin heating capacity actually increased with temperature.

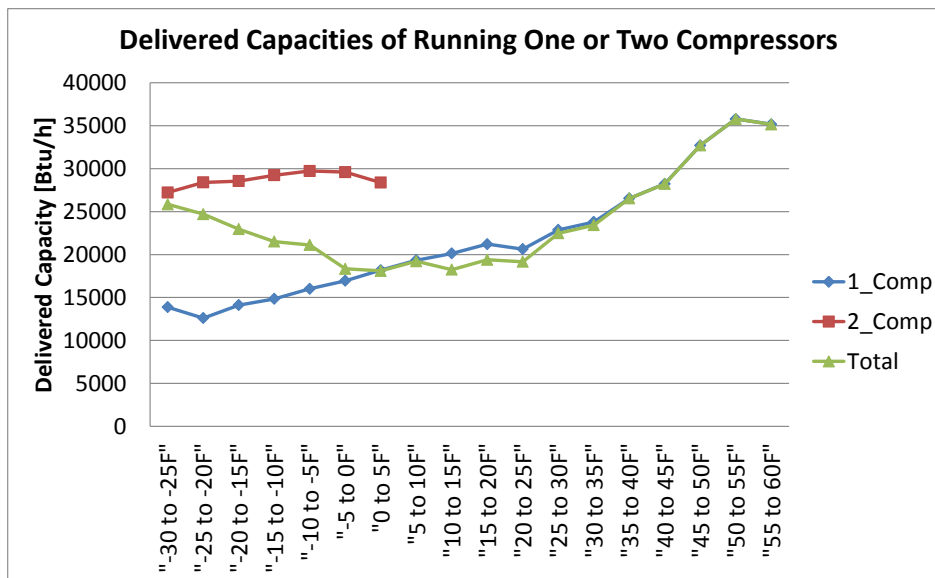

Figure 5: Delivered heat capacities of running one or two compressors

Figure 6 shows the average measured temperature rise in the indoor coil air stream across the indoor blower unit. The system room thermostat was set at 68°F (20°C), which caused the zone temperature to typically change from 66°F to 70°F (18.9°C to 21.1°C) over each heat pump run cycle. Recall that we allowed the indoor air flow rate to change with the compressor staging (High/Low) except for outdoor

temperatures above 42°F (5.6°C) when the blower ran at high speed for reasons noted earlier. The measured low indoor air flow rate was around 1200 CFM, and the high indoor air flow rate was around 1650 CFM. Because the field testing lab space has a lower load profile than a typical building, only a single-speed compressor was normally needed above 5°F (-15°C). At moderate ambient temperatures, e.g. above 25°F (-3.9°F), the heat pump cycled for most time. All these factors led to an approximately uniform temperature rise from the return to supply air around 15R.

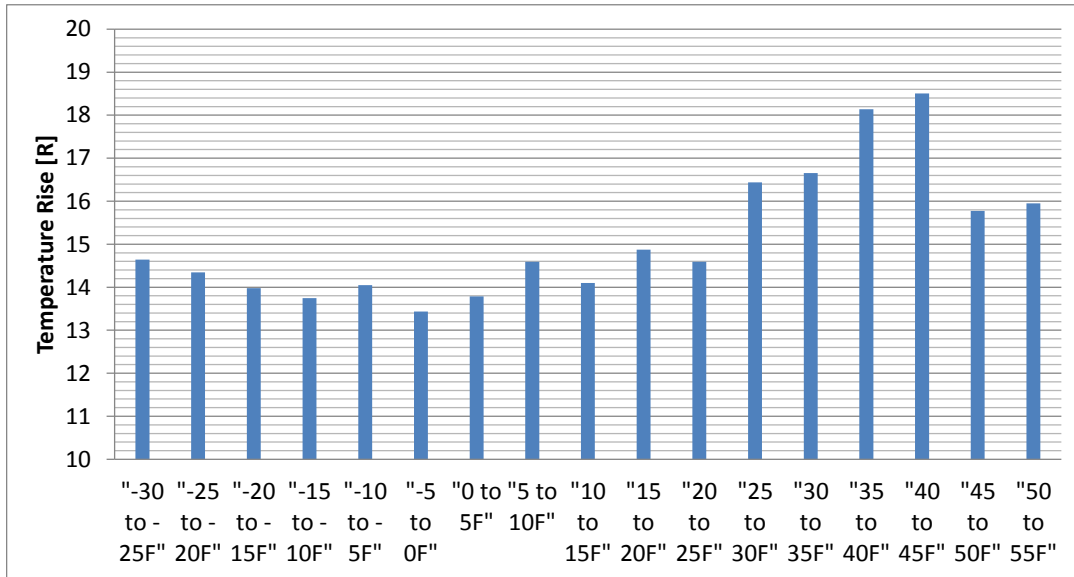

Figure 6: Average temperature rise from return to supply

Figure 7 presents the defrost cycle run time fraction relative to the total heat pump operation time. It can be seen that the defrosting frequency was minimal for the CCHP, for two reasons:

1. During the outdoor temperature range most conducive to outdoor coil frosting, only one compressor was operating most of the time and frost formation was slow. This was due to the outdoor coil being relatively oversized compared to the single compressor capacity leading to higher evaporating temperatures than typical for conventional air-source heat pumps.
2. When two compressors were needed at low ambient temperatures, the outdoor humidity level was very low and hardly any moisture condensed on the outdoor coil.

Because the EXV opening was controlled as a function of the ambient temperature, the defrost frequency appeared to peak in the 10-15°F (-8.3°C) outdoor temperature bin.

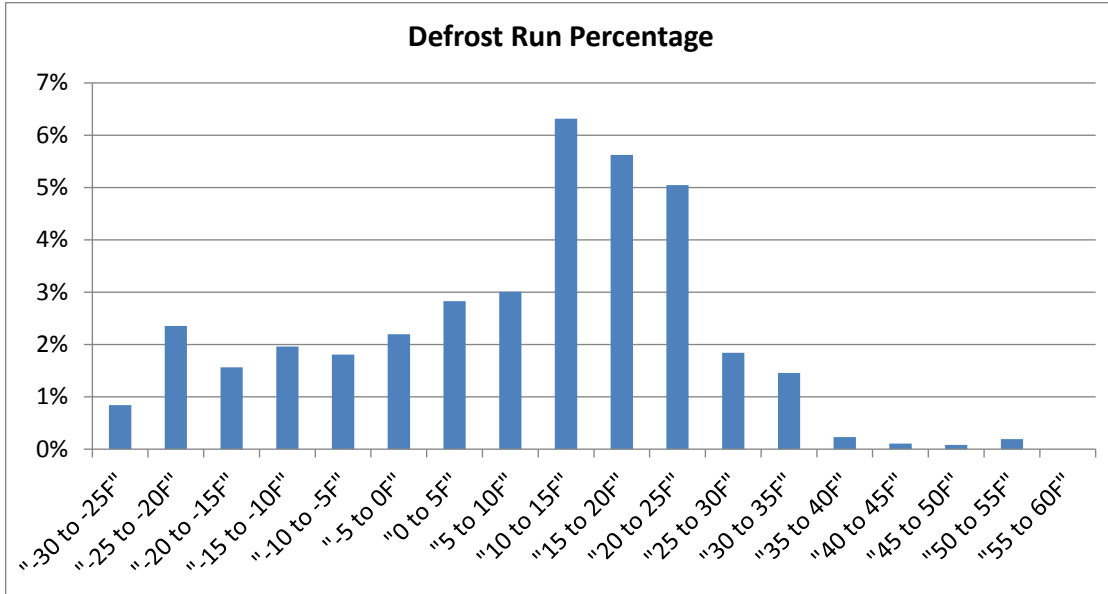

Figure 7: Defrost time ratio relative to capacity delivered in each bin

Figure 8 illustrates average field-measured bin COPs for both single- and dual-compressor operation. The total COP (or overall system average bin COP) was calculated by the total energy delivery divided by the total energy consumed, including loss effects due to cycling, frosting/defrosting, and switching between one or two compressor operation. The single- and two-compressor COP curves do not include the defrost loss effect. During the defrosting operation, the heat pump always ran two compressors in the reversed cycle. It can be seen for the 45°F to 50°F (7.2°C to 10°C) bin the total COP is 4.0. This is about 12% lower than that obtained in earlier lab measurements for steady-state operation because of the cyclic loss effects. It is encouraging to see that, at -30°F (-35°C), the total COP was about 1.8, i.e. 80% more efficient than resistance heating. The field COP at -13°F (-25°C) is around 2.0. It is also interesting to note that for ambient temperatures below about -15°F (-26°C), single compressor operation appears less efficient than dual compressor operation.

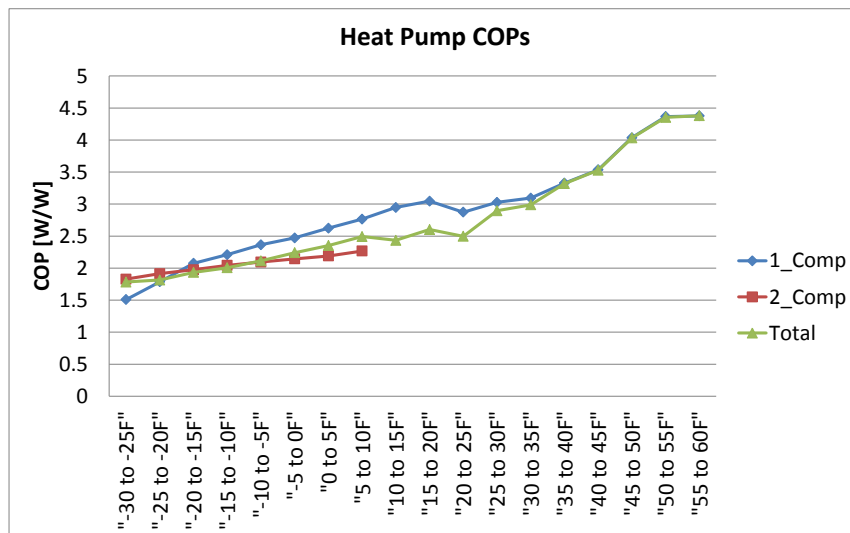

Figure 8: Field COPs in heating mode

3. Two Lessons Learned

- A low pressure compressor protection shut off control prevented system operation below about -30°F ambient due to a minimum suction pressure set point >30 psia. However, the compressors could have continued to operate at even lower temperatures. The compressor discharge temperature was around 230°F at the -30°F condition, far below the maximum discharge temperature limit of 280°F. A lower suction pressure protection setting would allow the CCHP to operate down to -35°F or perhaps even -40°F.
- The field testing site chosen had a low building heating load profile, and the CCHP was sized to match the peak building load around -30°F. This meant that two-compressor operation typically did not occur until the ambient temperature fell to around 5°F. The CCHP was able to provide enough heating capacity, but the indoor air flow rates appear too high to deliver comfortable supply air temperatures. A redesign of the indoor blower or reconfiguration of the blower speed settings to reduce the air flow rate would have boosted the supply air temperature and the indoor comfort level. However this would come at some system efficiency penalty due to higher condensing temperature in heating operation.

4. Summary

We developed a prototype air-source CCHP system using equal size tandem VI compressors, coupled with an inter-stage flash tank. The prototype was installed in Fairbanks, Alaska for field testing for the period of 09/2016 to 03/2017. The CCHP successfully operated down to -30°F and was able to meet the building heating load with good efficiency in a wide range of ambient temperatures. At -30°F, the CCHP delivered 75% heat pump capacity, relative to the capacity at 47°F, and the heat pump COP was 1.8.