

FOR REFERENCE ONLY

1 FRAME OVERVIEW

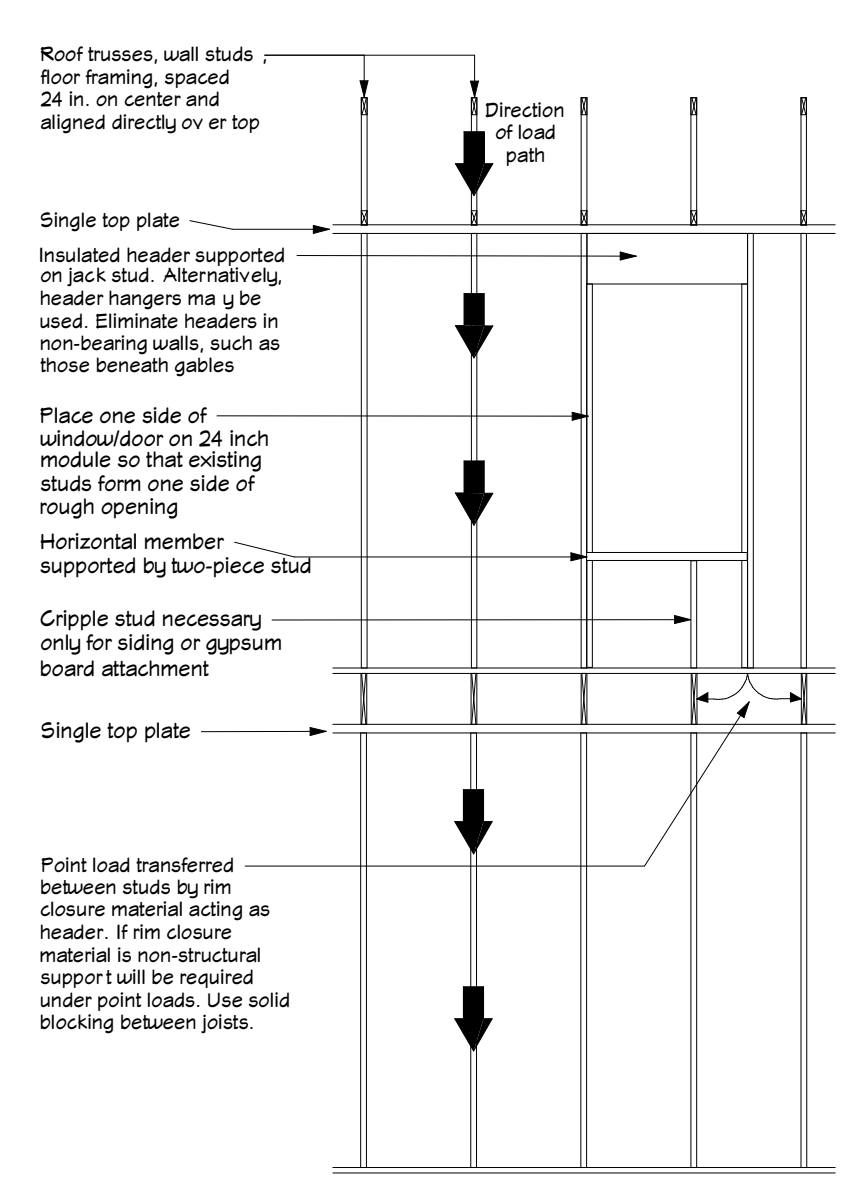

FOR REFERENCE ONLY

2 LOAD ALIGNMENT

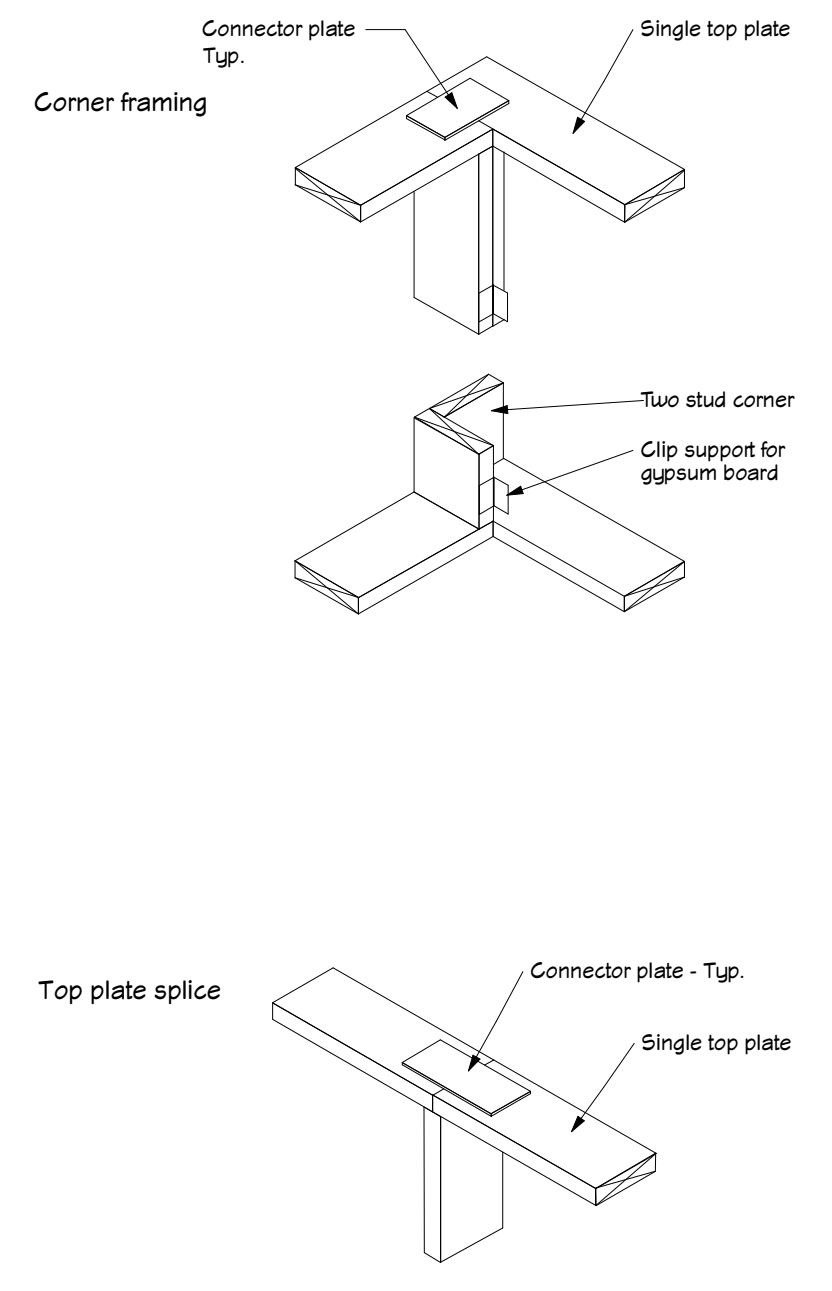

3 SPLICE DETAILS

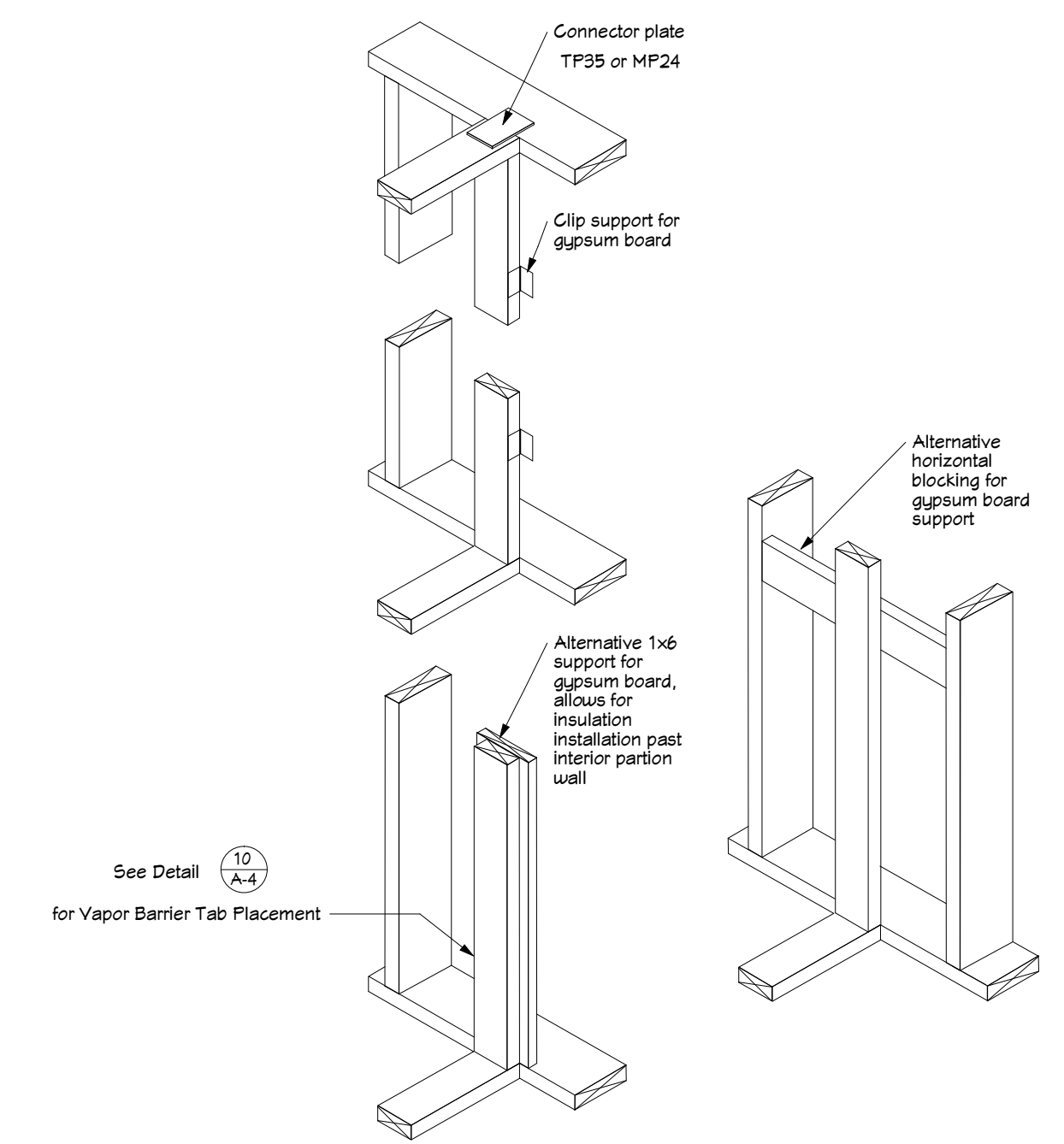

4 FRAMING DETAIL OPTIONS

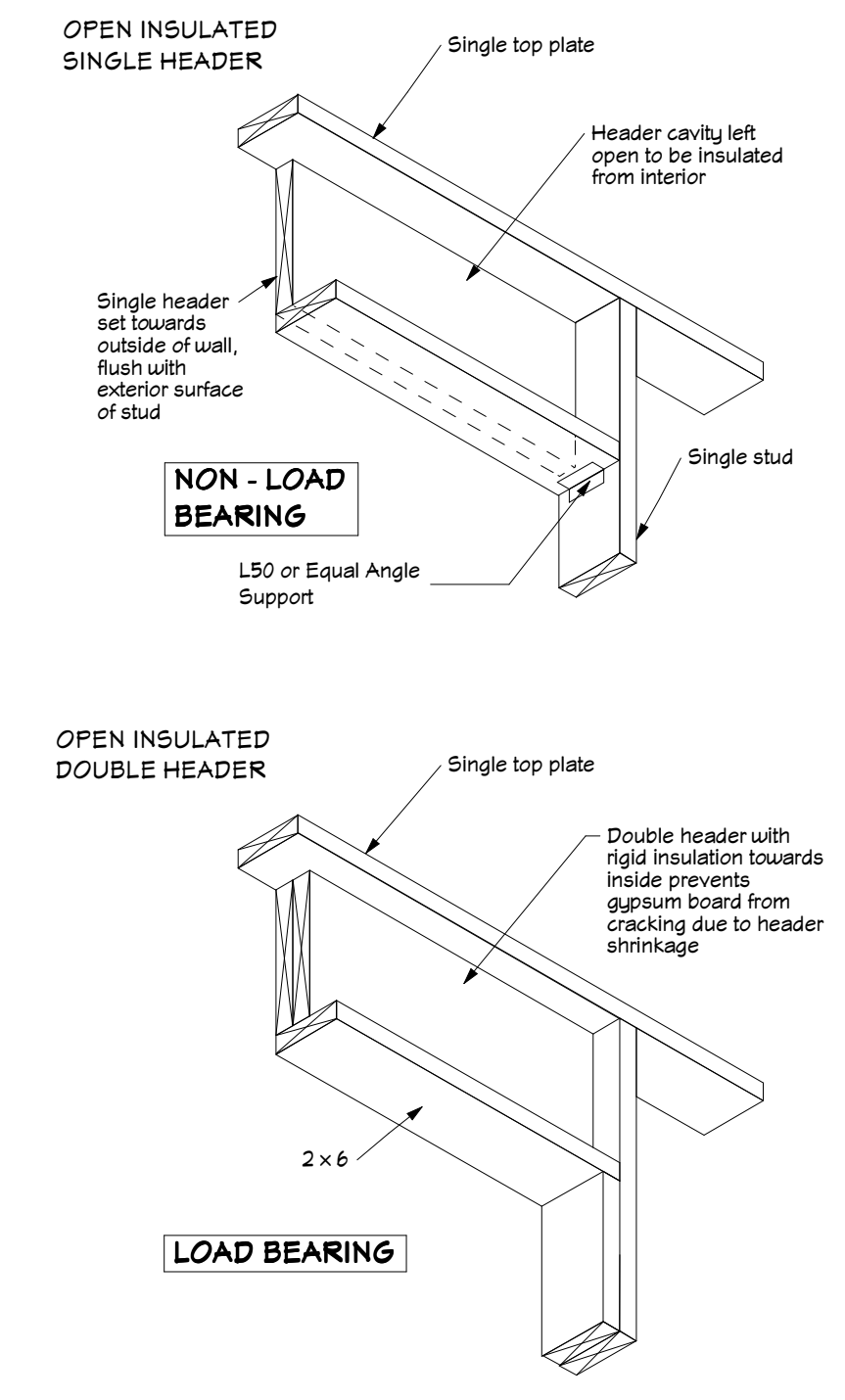

5 HEADER DETAIL OPTIONS

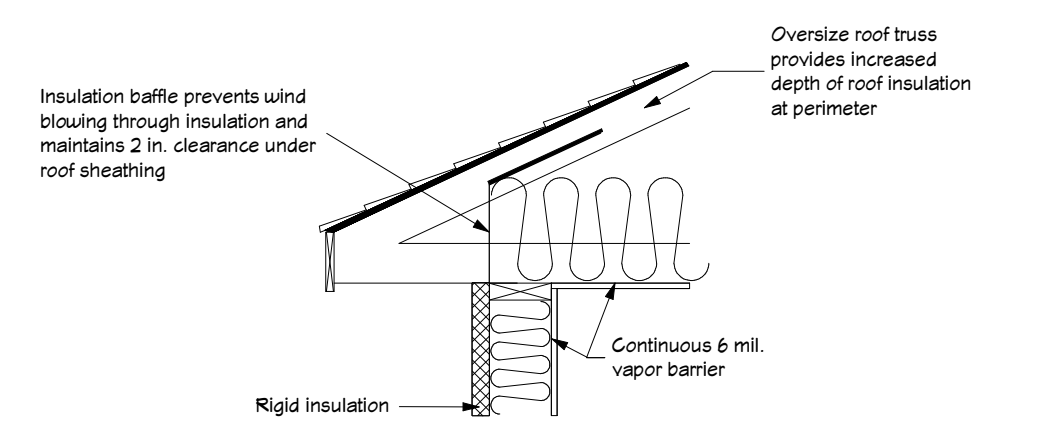

6 OPTIONAL EAVE DETAIL

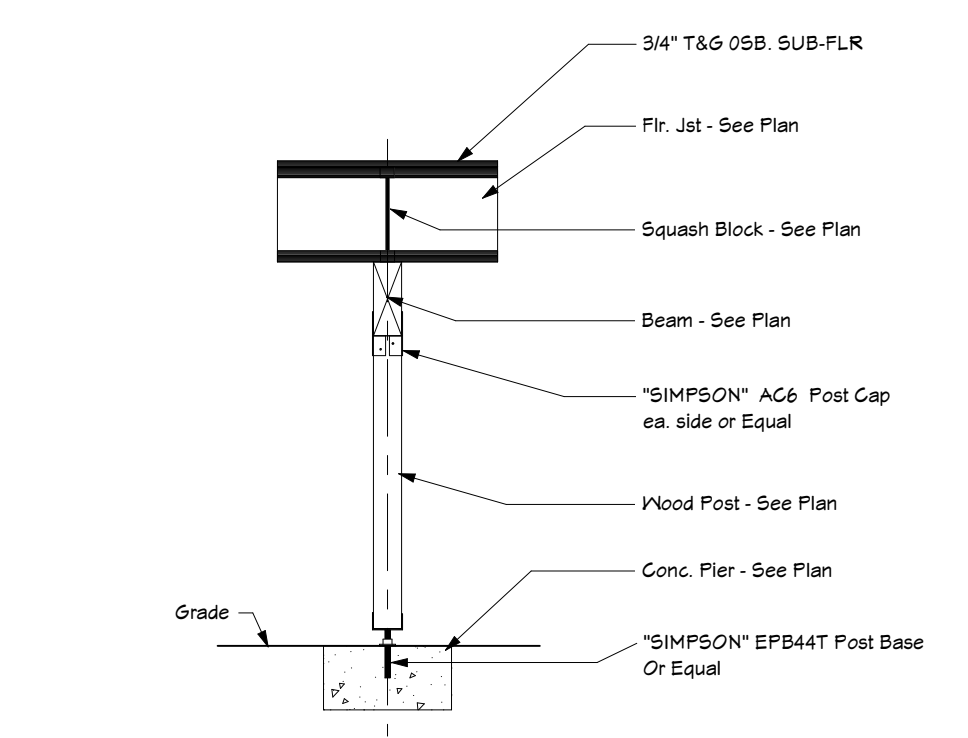

7 POST & PIER DETAIL

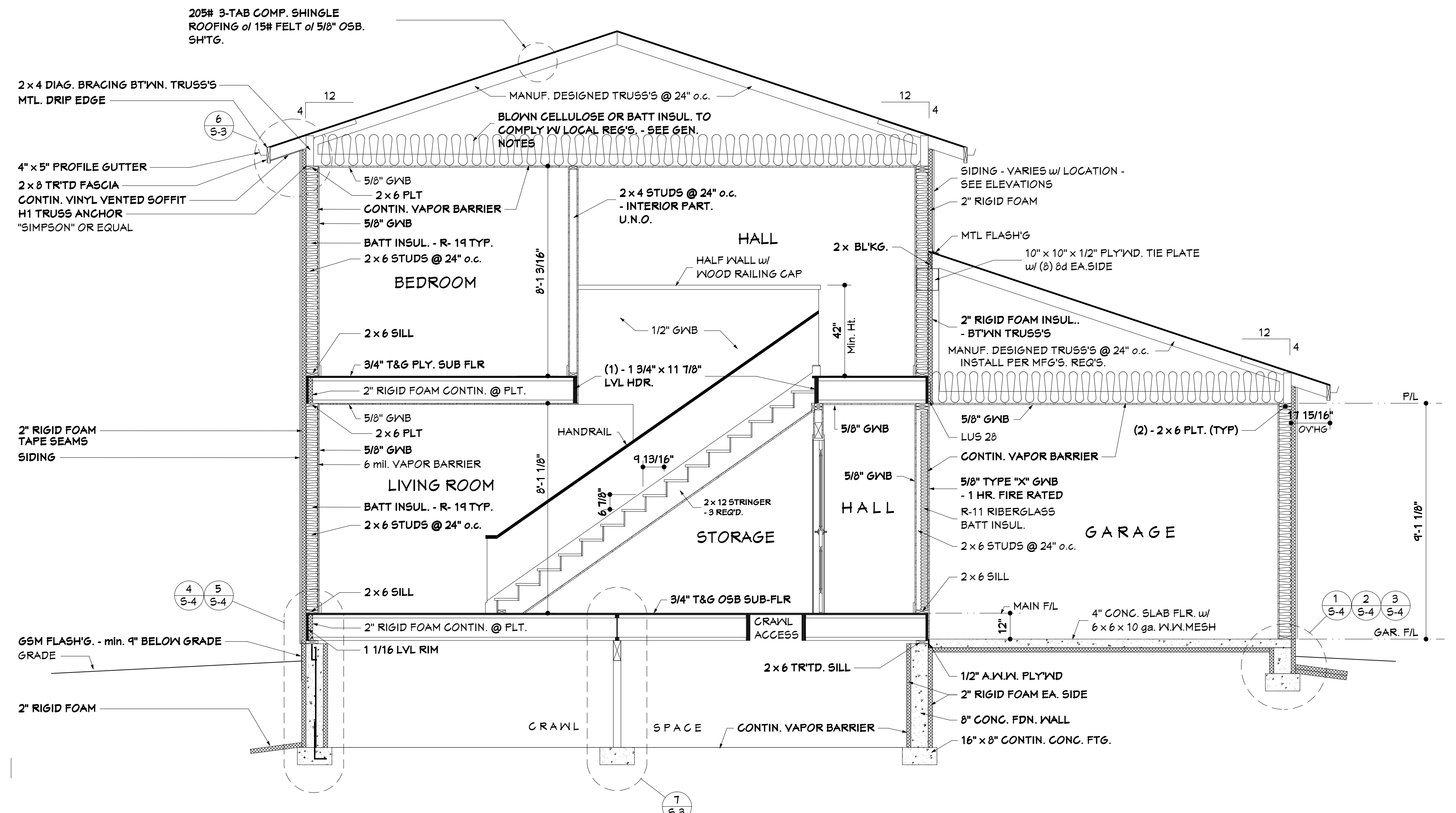

A BUILDING SECTION

3/8" = 1' - 0"

DATE: 10/29/2001  
 SCALE:  
 DRAWN BY: JF LOPEZ  
 DESIGNED BY: HEBERT CCHRC

COLD CLIMATE HOUSING RESEARCH CENTER  
 CCHRC  
 www.cchrc.org  
 515 - 7th AVENUE  
 FAIRBANKS, ALASKA  
 Ph: (907) 457-3454 Fax: (907) 457-3456

BUILDING SECTION  
 TYPICAL FRAMING DETAILS

REGION  
 INTERIOR ALASKA  
 SO. CENTRAL ALASKA  
 SOUTHEAST ALASKA

Building AMERICA IN ALASKA

SHEET  
 S - 3  
 OF 9